



The TRM turbomixers is used for rigid and soft PVC have shown themselves to be **extremely efficient in the thermoplastic materials** transformation industry.

When **good quality** material must be combined with **high hourly throughput**, this turbomixer is the ideal solution.

A perfect mix can only be achieved by using extremely high quality tools. Each manufacturing sector has different characteristics and needs which is why PLAS MEC provides a wide range of mixing tools. (more than 50 types).

### FEATURES

#### MIXING VESSEL

- Internal surfaces in contact with the material are made of stainless steel.
- Double or triple insulated jacket for the circulation of water or oil.

#### MIXING TOOL

- Made of stainless steel, with axial and radial mixing effect, designed to optimize distribution of the hot material on the cooling surfaces.

#### DISCHARGE

- Openable discharge outlet
- Double discharge outlet

#### LID

- Can be supplied in various configurations; it can be opened vertically thanks to a pneumatic cylinder operated lifting system.
- Intrinsic safety opening system with lead screw type mechanic or automatic actuator.
- Safety device only allowing the lid to be opened after the mixer has stopped moving.

#### TEMPERATURE CONTROL

- By means of thermocouple located at the side of the mixing vessel to control operating and safety temperatures.

Type	Total capacity litres	Weight per batch kgs (1)	Motor power kW (2)
TRM 200	200	90	45
TRM 250	250	110	55
TRM 300	300	140	75
TRM 400	400	180	90
TRM 500	500	220	110
TRM 600	600	260	132
TRM 700	700	310	160
TRM 800	800	360	200
TRM 1000	1000	450	250
TRM 1200	1200	540	315
TRM 1500	1500	675	355
TRM 2000	2000	900	450
TRM 2500	2500	1100	560

NOTE: The data in the table are given merely by way of example and will have to be confirmed by PLAS MEC.

(1) The mix weights are valid for PVC suspension formula with an apparent density of 0.55 Kg/l. inclusive of additives and for plasticized PVC suspension with a percentage of plasticizers not higher than 40 p.h.r.

(2) Direct current motors, AC, with frequency variators.

## OPENABLE DISCHARGE OUTLET

Facilitates and reduces cleaning times.



## COMBINED LID OPENING

Facilitates and reduces cleaning times.



## DOUBLE DISCHARGE OUTLET

Can be used to discharge the material into a second cooler.



## LIQUID INJECTION VALVE

Allows ideal absorption of liquid components in the mix.



## PROVISION FOR VACUUM APPLICATION

Allows complete elimination of humidity.



## FILTER SYSTEM

Self-cleaning filters for powder suction.



## VESSEL WITH DOUBLE / TRIPLE JACKET FOR HEATING

Oil / water heating / cooling.



Dimensions	A	B	C
TRM 200	1120	1950	1200
TRM 250	1080	2380	1410
TRM 300	1080	2380	1500
TRM 400	1180	2380	1500
TRM 500	1250	2650	1750
TRM 600	1250	2760	1830
TRM 700	1300	2760	1860
TRM 800	1450	2980	1900
TRM 1000	1500	3650	2050
TRM 1200	1650	3650	2050
TRM 1500	1650	3650	2300
TRM 2000	1850	3700	2550
TRM 2500	1850	3700	2800

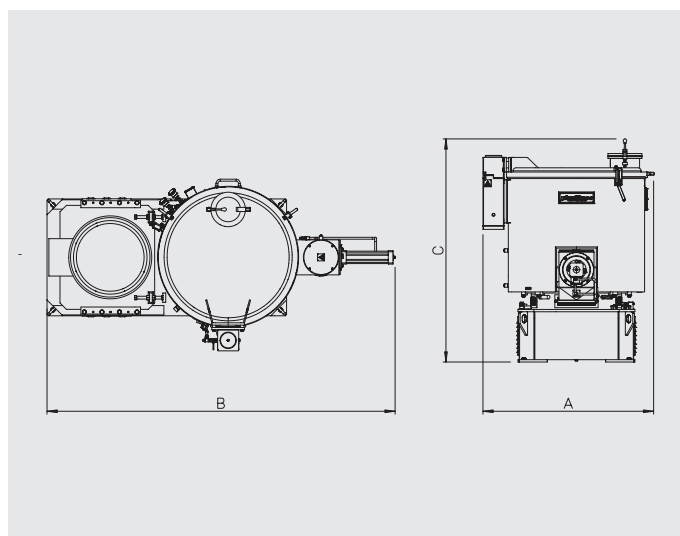

PVC DRY BLEND, POWDER COATINGS, MASTERBATCH AND PIGMENTS, THERMOPLASTIC RUBBERS, WOOD PLASTIC COMPOSITES AND MORE...

**PLAS MEC S.R.L.** Mixing Systems for Plastics and Powder Coatings

Via Europa, 79 - 21015 Lonate Pozzolo (VA) - ITALY - Tel. +39 0331 301648 (r.a.) - Fax +39 0331 301749 - mail: comm@plasmec.it - [www.plasmec.it](http://www.plasmec.it)



100% MADE IN  
**PLAS MEC**