



Horizontal cooler combination is the combination of the heating mixer TRM and the high efficiency horizontal cooler HEC.

The HEC range of coolers used for this combination, can be applied to any type of turbomixer TRM and this **is the ideal solution for all manufacturing needs in the field of rigid or plasticized PVC dry-blend**. This equipment is built entirely of stainless steel as regards the parts in contact with the material and double or triple jacket for circulation of cooling water. Available with **capacities from 250/800 lt. up to 2.500/8.500 lt.**, the HC COMBIMIX stands out for its great and proven efficiency, allowing excellent throughput and high standards of quality.

Type	Hourly production kg/h	
	Rigid PVC	Plasticized PVC
HC 250/800	880	630
HC 300/1000	1100	760
HC 400/1000	1400	1020
HC 500/1500	1750	1260
HC 600/1500	2100	1530
HC 700/2500	2500	1800
HC 800/2500	2900	2040
HC 1000/3500	3600	2550
HC 1200/3500	4300	3000
HC 1500/4500	5400	3840
HC 2000/5500	7200	5100
HC 2500/6500	8800	6300

NOTE: The data in the table are given merely by way of example and will have to be confirmed by PLAS MEC.

(1) Valid for fully-automatic operation with final temperature of 120°C for turbomixer and 45°C for cooler but only when cooling water flow is sufficient and the water temperature is no higher than 15°C.

Dimensions	A	B	C
HC 250/800	2720	2800	2970
HC 300/1000	2900	2800	3060
HC 400/1000	2900	2850	3000
HC 500/1500	3100	3200	3300
HC 500/1800	3500	3200	3300
HC 600/1500	3100	3200	3400
HC 600/1800	3500	3200	3400
HC 700/1800	3550	3200	3600
HC 700/2500	3800	3400	3600
HC 800/2500	3800	3600	3600
HC 1000/3500	3950	3850	3750
HC 1200/3500	3950	4250	3750
HC 1500/4500	4150	4250	3900
HC 2000/5500	4950	4450	4250
HC 2500/6500	4750	3500	4350
HC 2500/8500	5900	3550	4450

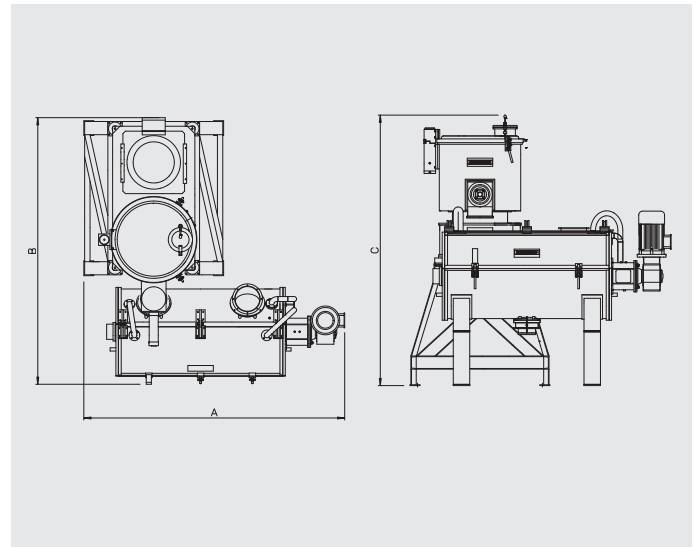

DGL – LIQUID WEIGHING UNIT

PLAS MEC Liquid Weighing unit DGL are always design to suit customers individual requirements. **This systems is used in all processes where precision and consistent feeding of the Production plant is required.**

Integration with control systems permits, through precise and constant control of flow rates, **production optimization by improving the dispersion and homogenization of the products and eliminating waste and down - time.**

The system allows a constant flow rate to be maintained and number of products to be mixed by way of regulated batching. Recipes with their respective control parameters can be called up, edited and put into production from a series of screen pages, possibility of dosing up to 12 components. This unit can be customized according to customer needs.

Type	Capacity kg
DGL 10	10
DGL 15	15
DGL 20	20
DGL 25	25
DGL 30	30
DGL 40	40
DGL 50	50
DGL 100	100
DGL 150	150
DGL 200	200
DGL 300	300
DGL 400	400
DGL 500	500

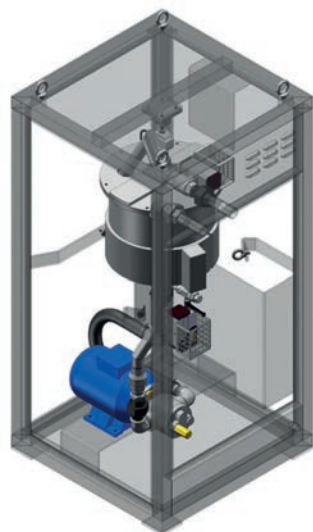

CRS BAG EMPTYING UNIT

Semi-automatic unit for feeding powder (PVC / CAC03 / Stabilizers) from bags into the mixer, consisting of a **bag-emptying mechanism located on the ground**, fitted with powder intake system and self-cleaning filter, the feeder hopper is positioned on the top of the turbomixer.

Type	Suitable for
CRS/1	TRM 200 / 250 / 300 / 400 / 500
CRS/2	TRM 600 / 700 / 800
CRS/3	TRM 1000 / 1200 / 1500 / 2000 / 2500



PVC DRY BLEND, POWDER COATINGS, MASTERBATCH AND PIGMENTS, THERMOPLASTIC RUBBERS, WOOD PLASTIC COMPOSITES **AND MORE...**

PLAS MEC S.R.L. Mixing Systems for Plastics and Powder Coatings

Via Europa, 79 - 21015 Lonate Pozzolo (VA) - ITALY - Tel. +39 0331 301648 (r.a.) - Fax +39 0331 301749 - mail: comm@plasmec.it - www.plasmec.it

